



W Collection

W7OSPBLAUS

BUILT-IN SELF CLEANING ELECTRIC OVEN



FEATURES & BENEFITS



MULTIFUNCTION 8

Multiple cooking methods. The Multifunction 8 feature offers flexible cooking options, to ensure perfect results, whatever the recipe.



6TH SENSE

No more guesswork. Simply pick your recipes, and let 6th SENSE cook them to perfection, every time. Up to 40 cooking combinations organized to fit your lifestyle and diet, for a full assisted cooking experience.



READY2COOK

No pre-heating required. The Ready2Cook function uses a powerful convection system to quickly reach the right temperature, and completely eliminate the need for pre-heating.



STEAMSENSE

A combination of heat and steam injection with three levels of steam to cook your favorite recipes and get soft, crispy and juicier results. It maintains the nutrients and enhances taste.



FORCED AIR

Seal in the taste. Thanks to the Forced Air technology, preheated air is circulated inside your Oven using an innovative convection system, giving you moist, juicy cooking results.



SOFT CLOSING

Slow-motion closing. Thanks to slow-closing hinges, the oven door shuts effortlessly, with a soft and silent motion.



WARRANTY

Guarantees peace of mind and value for money knowing that any product fault or defect is covered by full replacement parts and/or a service call to ensure the product works as described.

TECHNICAL SPECIFICATIONS

COLOUR/FINISH	Black
DISPLAY	LED Digital
CONTROL	Electrical
DOOR / HANDLE DESIGN	Full Glass Door with Black Handle
CAVITY TYPE	Enamelled
CAPACITY	73 litres
CLEANING	Pyrolytic
PRODUCT DIMENSION	W 595mm x H 595mm x D 564mm
FEATURES	Cook4, Ready2Cook, Defrost function, SteamSense, Forced Air Fan Cooking, Turbo Fan, Grill, Easy Clean Enamel Interior, Turbo grill, Maxi cooking, Pastry function, Pizza/Bread function
MAX. TOTAL POWER	3300W
VOLTAGE	220-240 V
CURRENT	16 amp
ELECTRICAL CORD	90cm
NET WEIGHT	40.5kg
WARRANTY	Five Year Parts and Labour

INSTALLATION GUIDE

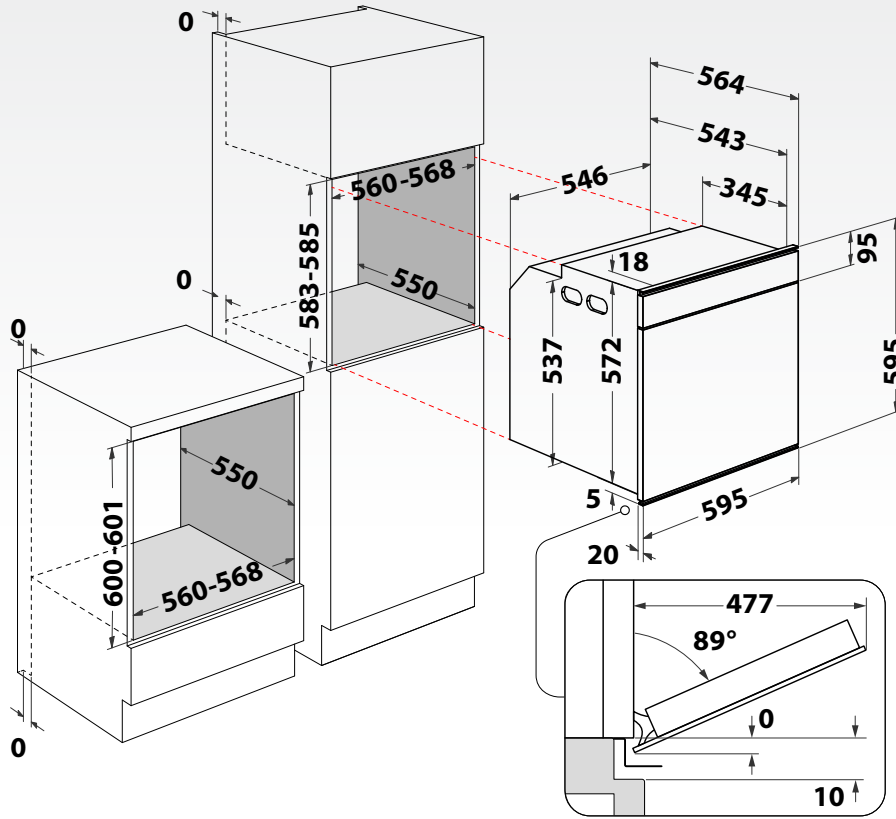

CONTROL PANEL

